

## Active Balancing

# Electromagnetic Ring Balancer AB 9000

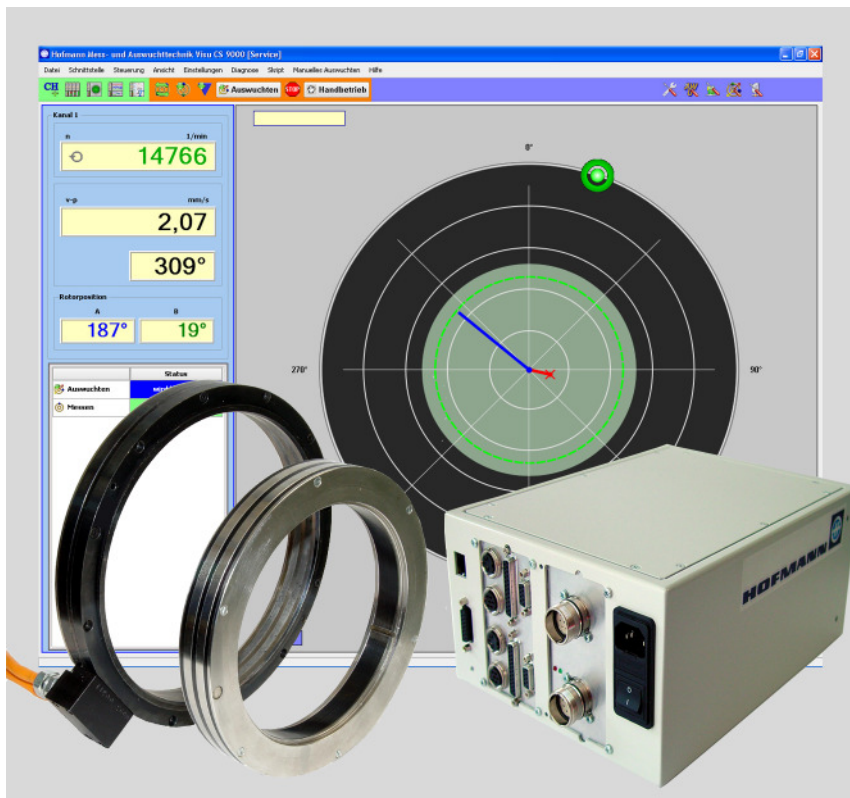

### Advantages

- Ring design for universal adaptation
- Time savings through fast electromagnetic drive and adaptive balancing methods
- Increased product quality and machine availability
- Suitable for very high speeds
- Permanent vibration monitoring
- Neutral position for manual pre-balancing
- Windows operating and visualisation software
- Field balancing software

### Applications

- Balancing during machine operation
- Compensation of operational unbalances
- Achieving perfect running condition
- Monitoring unbalance vibrations
- Generating unbalance for system identification or acceptance tests

### Description

#### Principles of operation

The active balancing system AB 9000 automatically compensates unbalance during the operation of a machine. Therefore two balancing rotors are built into the rotating part of the balancing unit. These rotors rotate freely on the rotational axis. If the rotors' balancing weights are positioned directly opposing each other, their effect is neutralised. The full balancing capacity is obtained by placing the weights at the same angular position. By moving the weights to a specific angle, any unbalance correction with respect to magnitude and angle can be obtained within the mentioned limits.

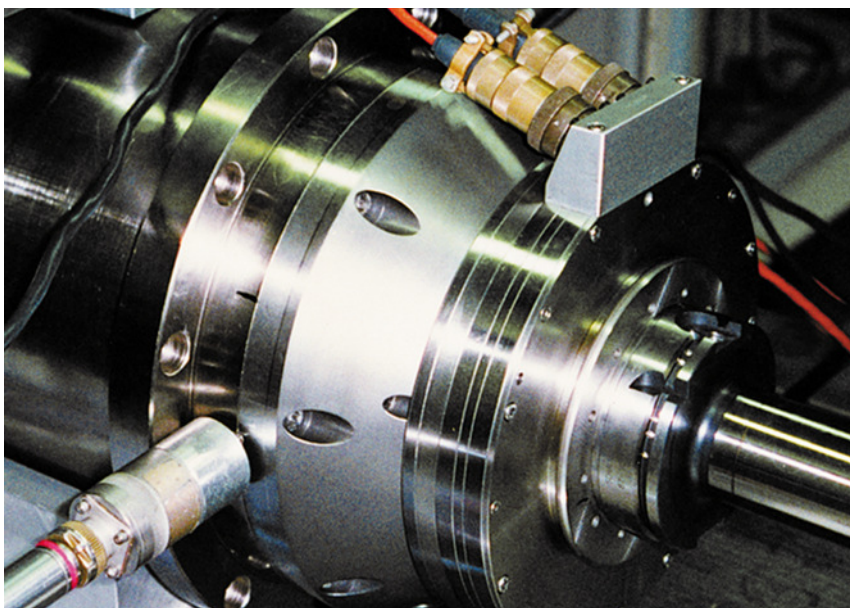

HSC spindle with AB 9000 balancing unit

The measured information - rotor speed, angular position of balancing rotors and vibrations - are captured by a fast controller unit using adaptive algorithms. If the vibration exceeds preset limits, an automatic balancing run is started. The balancing rotors are moved by activation of the stator coils.

**System characteristics**

AB 9000 balances using a direct adaptive procedure. The positions of the balancing rotors required to compensate the unbalance are

calculated based on the actual measuring data. Thus, only a minimum number of balancing steps are required not only for one plane balancing but especially if two planes need to be balanced automatically.

As the system adapts to new boundary conditions after each corrective step, changes of a machine's dynamic transfer properties due to temperature or speed changes pose no problem whatsoever.

With its ring configuration, the AB 9000 can be easily incorporated in new or existing machine designs. The balancing units are perfectly suited for a wide range of temperatures. Corresponding shaft expansion is automatically compensated.

The setting and operation of the AB 9000 as well as the visualisation of the automatic balancing process is handled by a PC software. The software runs on a PC/laptop or is directly installed on the PC of a machine control.

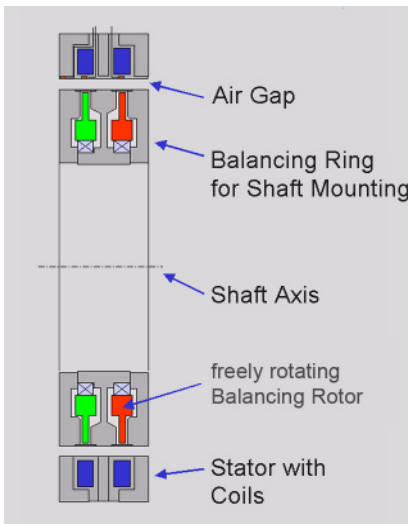

Sectional view (schematic) of balancing unit BU 9000

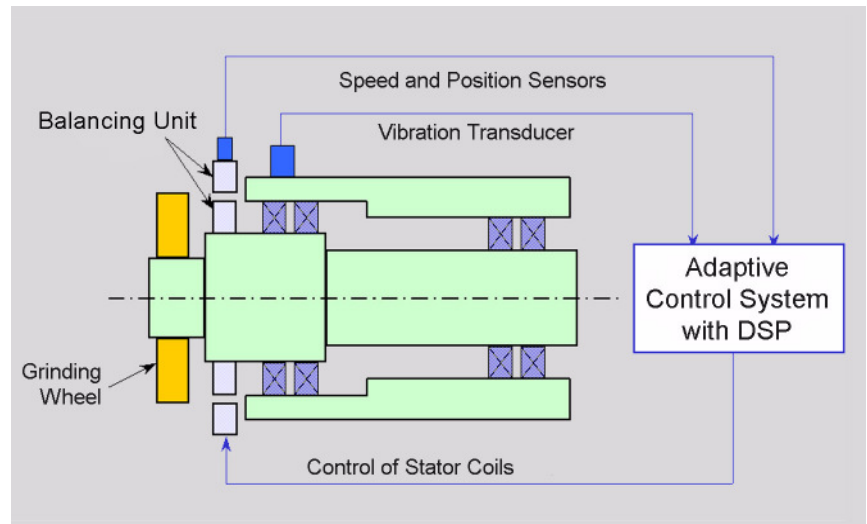

Components of the balancing system AB 9000

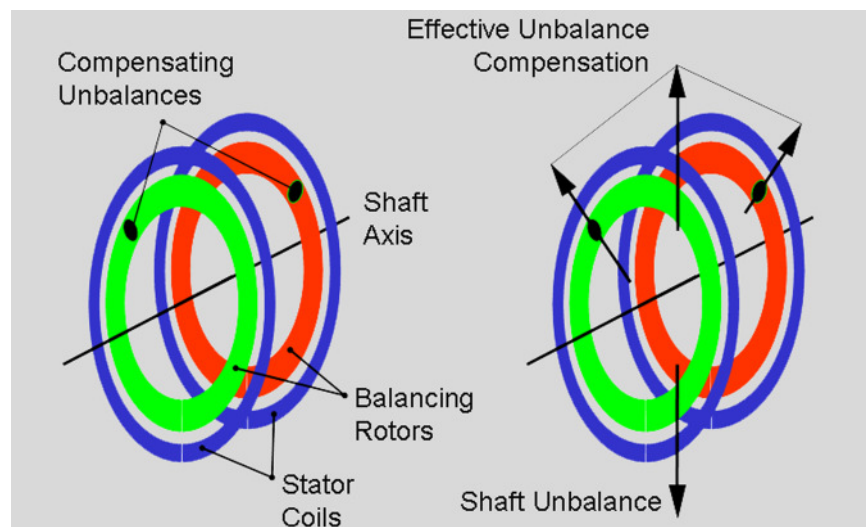

Principle of operation

The software also includes field- or pre-balancing in case the rotor unbalance exceeds the balancing unit's capacity. For the pre-balancing run, the balancing rotors are moved in neutral position to correct only rotor unbalance; thus, preventing the consumption of balancing capacity.

## Application examples

### Machine tools

- Automatic balancing of grinding wheels and grinding spindles
- Balancing after a tool change on HSC spindles
- Compensation of chucks with asymmetric workpieces, i.e. in a lathe.

### Process industry

- Fans, compressors - correction of unbalance due to trash buildup, dirt accumulation.
- Paper rolls - compensation of unbalance due to thermal distortion, condensate build-up
- Pumps - compensation of hydraulic unbalance

## Scope of supply

- Balancing unit BU 9000 consisting of balancing ring and stator with sensors
- Controller AB 9000
- Vibration sensor
- Cordset
- PC software CS 9000
- Operating instructions



Large radial fan with installed balancing unit

1 Balancing ring, 2 Stator mounting adapter, 3 Bearing housing, 4 Vibration sensor

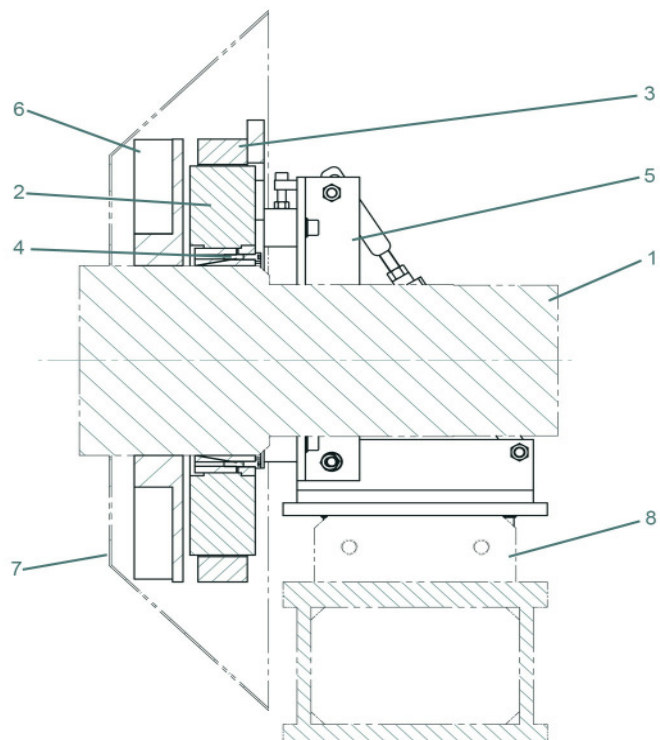

Balancing unit BU 9000 - fan installation

1 Fan shaft, 2 Balancing ring, 3 Stator, 4 Shaft adapter, 5 Stator mounting bracket, 6 Cooling wheel, 7 Fan housing, 8 Pedestal

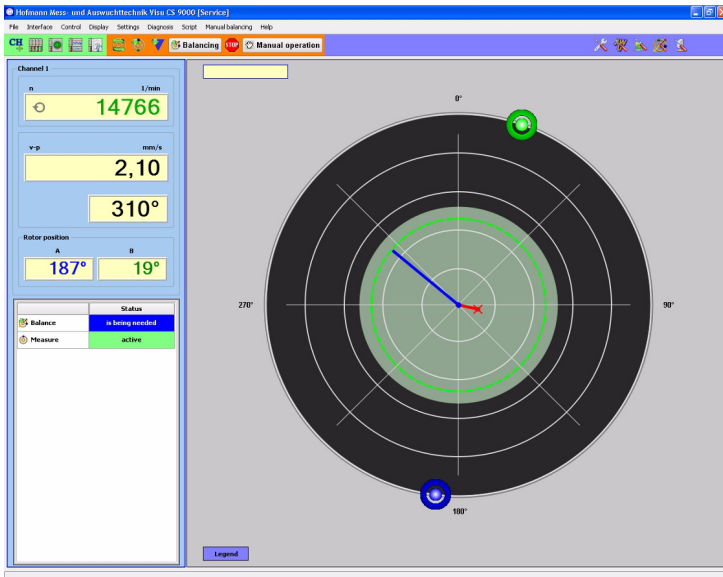

CS 9000 - HMI-software

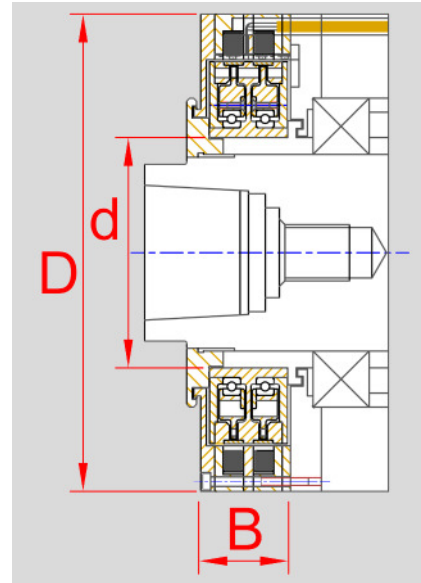

BU 9000 - spindle installation

## Technical data

### Ring balancing units BU 9000

(typical data of balancing units other designs or applications upon request)

Type	68	76	89	108	121	165	229	406
Balancing capacity [1,000 gmm]	0.9	0.2	0.4	0.2	1.0	1.5	13.0	3,240
Max. balancing speed [1/min]	10,000	22,000	16,000	5,500	9,000	8,000	8,000	1,200
Balancing time [s] (dep. on size of unbalance and meas. parameter)	4 - 12	5 - 12	5 - 16	6 - 20	8 - 25	10 - 30	12 - 60	50 - 150
d [mm]	63.5	68	82	95	115	160	209,8	355
D [mm]	132	160	170	192	203	250	350	700
B [mm]	35	31,5	29	34	33	33	35	94

### Controller AB 9000

Balancing planes	1 or 2	1 or 2
Max. no. of controllable balancing units	2	4
Speed range	200 to 120,000 1/min	200 to 120,000 1/min
Vibration sensor		
Accelerometer	z.B. HMA 1830	z.B. HMA 1830
Velocimeter	z.B. PMG 81	z.B. PMG 81
Vibration display	µm, mm/s, m/s <sup>2</sup> , g	µm, mm/s, m/s <sup>2</sup> , g
Range	0,01 to 1,000 µm depending on speed and used vibration sensor	0,01 to 1,000 µm depending on speed and used vibration sensor
PC interface	RJ 45	RJ 45
PLC interface	D-Sub 25 and D-Sub 9	D-Sub 25 and D-Sub 9
Dimensions (BxHxT) in mm	210 x 120 x 280	483 x 120 x 280
Power supply	230 V, 50 - 60 Hz, 400 W	230 V, 50 - 60 Hz, 400 W

**All information without obligation,  
subject to change without notice!**