

Active Balancing

HydroBalancer HB 6000

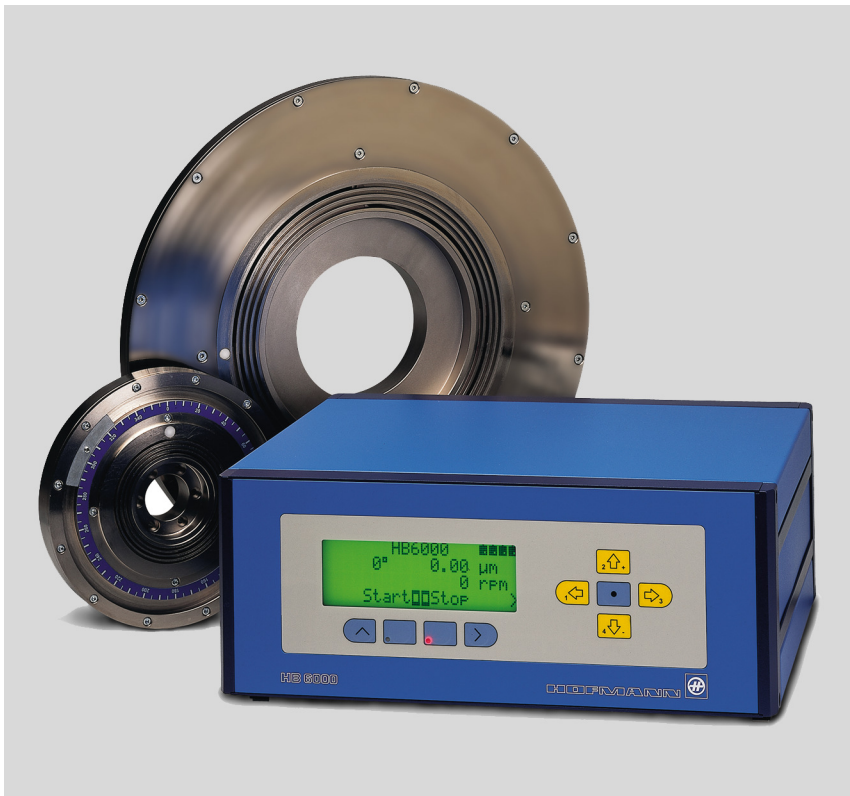

Advantages

- Increase in product quality and machine availability
- Permanent vibration monitoring
- Integration of ring container into spindle
- Software for manual pre-balancing

Applications

- Automatic balancing of Grinding Wheels
- Balancing during operation
- Compensation of unbalance in one or two balancing planes
- Achieving perfect smooth running
- Monitoring of unbalance vibrations

The unbalance compensation is achieved by controlled injection of liquid into the container chambers. Any correction size and direction can be generated within the limitations of the capacity as determined by the container design. Should the balancing capacity not be sufficient, a manual pre-balancing can be performed using the balancing software incorporated into the HB 6000 control unit.

A control unit constantly receives the measured data - rotational speed and vibrations. If the vibration exceeds a preset limit, an automatic balancing procedure is started by either the machine's PLC or the user. The HB 6000 balances automatically in either one or two planes using an iterative procedure based on the actual measurement data.

Description

The active balancing system HB 6000 compensates rotor unbalance using the component method. A four chamber ring container constitutes the balancing head.

The fluid is injected into axial annular grooves of the container as it rotates. From there the fluid flows through an opening into the respective chambers of the container. A fixed nozzle block is positioned directly opposite the annular grooves. Solenoid valves release the fluid and insure that it is sent through a specific nozzle into the required annular groove and ring chamber. The chambers are emptied once the spindle stops rotating.

The ring containers are integrated into flanges or mounted as a separate part onto the rotor axis. The containers' balancing capacity depends on size. The speed sensor is integrated in the nozzle block or mounted externally. Balancing liquids are either available directly on the machine (i.e. grinding oils or emulsions) or they are provided in open or closed circuits.

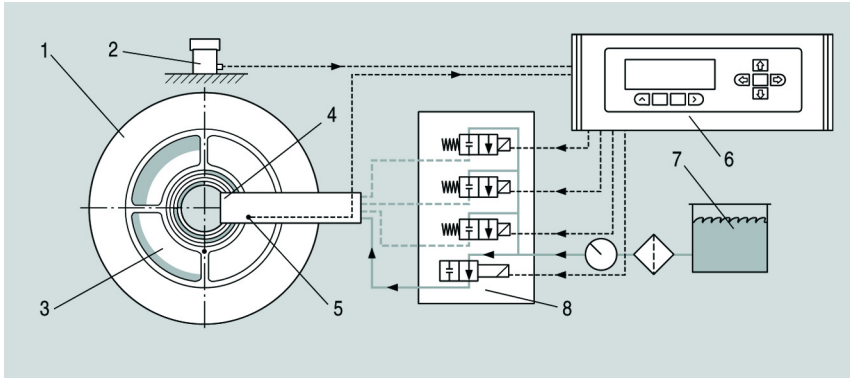

- 1 Grinding wheel
- 2 Vibration transducer
- 3 Ring container
- 4 Nozzle block
- 5 Speed sensor
- 6 Control unit
- 7 Coolant
- 8 Valve block

HB 6000 function schematic

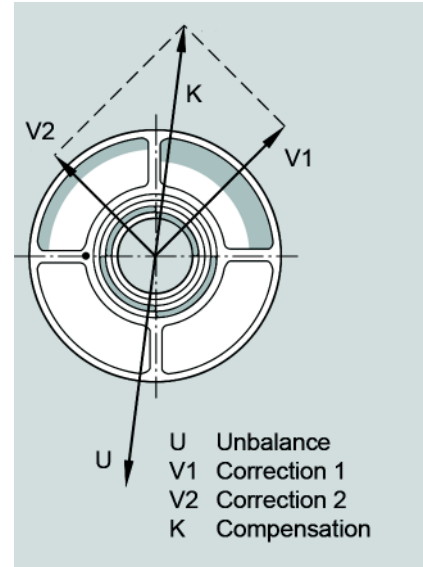

Unbalance compensation

Technical data

Measuring electronics	
Balancing planes	1/2
Vibration transducers	1/2
Rotational speed range	300 -100,000 RPM
Vibration displacement range	0.01 - 100 μm_{RMS}
Control panel	IP67, keypad with pressure point
Display	4x20 LCD, illuminated
I/O interface	24 V, 25 pin D-Sub
Dimensions WxHxD	
■ 19" rack mount unit	482 mm x 134 mm x 300 mm
■ Table top unit	345 mm x 133 mm x 300 mm
Power supply	115/230 V, 50-60 HZ, 80 W
Weight	approx. 6 kg

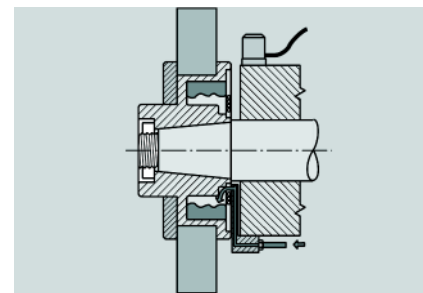

Ring container, flange integrated

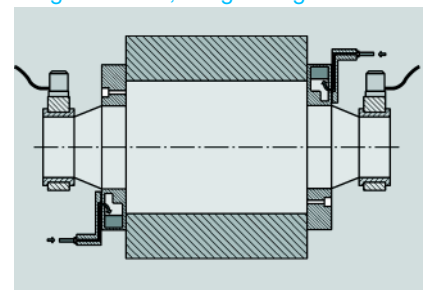

Dual plane balancing



Part of the scope of supply

Options

- Separate ring container for flange or spindle integration
- Control unit available as a 19" rack mount unit or table top unit
- Control unit with separate 19" operator panel
- External speed sensor

Scope of supply

- Control unit
- Ring container
- Vibration sensor SA 5005 with 4 m connection cable
- Valve block with 10 m connection cable
- Nozzle block with integrated speed sensor
- Filter element
- Pressure controller

All information without obligation, subject to change without notice!